

WPPOA NEWS

VOLUME 18, ISSUE 5

May 2015

Board Meeting Dates

June 15

July 20

August 17

September 21

October 19

November 16

December 21

**All meetings are held
on the third Monday
(except where noted)
at 3:00 p.m. at the
Property Owners' Office.**

Important Reminders from the POA

The Chukker Creek
(South) gate will
close for the
summer beginning
June 4, 2015.

The POA office
will be closed
Monday, May 25 in
observance of
Memorial Day. The
office will reopen
Tuesday, May 26
at 8 a.m.

PRESIDENT'S REMARKS Larry Wittenmyer

STORM:

Once again, we have been "blessed" with another storm! This time it was an F2 Tornado that did some significant damage in the Plantation. The brunt of the storm was felt in Hollow Creek and around the Juniper Lane area. Many trees were uprooted or snapped off, with some hitting homes causing damage. The Woodside Plantation CC golf courses were closed for a week to allow for clean-up. The Reserve Club courses were less affected, but they were closed for a couple of days, as well. The good news is that there were no injuries and most homeowners were without power for only a few hours. Our recovery was much faster than after last year's ice storm because the City responded quickly (within an hour) and removed downed trees from streets so traffic could get through. Once again, our residents jumped into action by cutting up and clearing out limbs and smaller trees, in their neighborhoods. Thanks to all who helped with our clean-up! I also want to give a big thank you to Mary Shultz, our Director of Common Area Landscaping for surveying the Plantation immediately following the storm and marshalling up the contractors to begin the clean-up process. Let's hope we have seen the last of these weather related problems, for a while.

Property Owner Decal Renewal Is Almost Over!

As a reminder, you have only a few days until the end of May when you will need to renew your vehicle decals for the New Year. You will need to bring your current registration or lease agreement to the WPPOA office to obtain your new decals. Help us to help you by not waiting until the last day (May 29th) to get your new decals. Thanks!

PRESRT-STD
U.S. POSTAGE
PAID
Augusta, GA
Permit No. 545

*Woodside Plantation
Property Owners' Association*
1411 Silver Bluff Road • Aiken, South Carolina 29803



COMMON AREA LANDSCAPING

Mary H Shultz

WHAT'S HAPPENING

Wooded Area Management: Once again the truism of "the best laid plans of mice and men oft' go awry" has evidenced itself. Because of the tornado on 4/19, significant damage was incurred to several areas of Woodside Plantation common areas. Areas along Woodside Plantation Drive in the vicinity of Juniper Lane, the island in Juniper Loop, various areas along our perimeter fence, Anderson Pond Gate area, and several other areas were severely damaged. Aiken city personnel were on site almost immediately, removing downed trees that blocked our streets and we also hired a tree service company to begin the clean up. This effort is continuing and will take precedence over the clean up of the remaining ice storm issues. As of May 6, Woodside Plantation Drive and Juniper Loop work has been completed. What remains are the efforts on Boxwood, Anderson Pond, Steeplechase at Reserve Park, and Sterling Grove Circle, all of which should be completed prior to the end of May. Currently, including the

remaining work, we will have spent approximately \$24,500 to remediate all work reported that is attributable to the tornado. A complete accounting of the costs will be reported in the next newsletter.

Grass Maintenance: Because of recent higher temperatures, the rye grass will begin to deteriorate. Therefore, our roadway grass may not look as healthy for awhile. In addition, the grass will be cut much shorter. After a few weeks, it should look just fine.

COMMON AREAS STILL USED FOR DUMPING: People still seem to think it is OK to place their yard debris on common areas. If we find debris on common areas next to your home, be advised you will be fined the amount it costs to remove the debris. After having cleaned up Woodside Plantation Drive, a service for which we had to pay, another pile of debris appeared. Please place your debris **ONLY** in front of your home. The City will not pick up debris along streets where there are no residences.

COMMUNICATION, TECHNOLOGY, ETC.

I want to thank the Residents that attended the recent Woodside POA Town Hall Meeting and the Fire Wise Presentation. The Board continues to try and improve communication with Residents and these are examples of that effort. The current intent of the Board is to have at least one Town Hall Meeting a year in addition to the Annual Meeting. Based on topics, interest and need, the Board may hold another Town Hall Meeting in the August timeframe.

In another effort to improve communication, the Board is in the process of redesigning the Woodside POA Web Page (found at www.wppoa.com). The intent is to give our current web page a more current and appealing look and feel. One additional element that will be added is a Residents only section. This section will be password protected. This section will contain information that the Board wants to share with Residents and not with the rest of the world. You will receive more information about this as we get closer to the web page launch.

In closing, a key way we communicate with Residents regarding time sensitive information is through email. To update your email address, send a note to wppoa@wppoa.com

MEMORIAL DAY

We honor the men and women of the U.S.
Armed Forces who have fought for and
are currently defending the
freedom our country enjoys.



APRIL 20, 2015 BOARD MEETING MINUTES

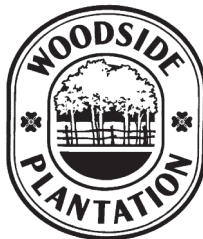

Meeting was called to order by President Larry Wittenmyer at 3:01PM at the WPPOA office conference room and a quorum was established.

Attendees: Larry Wittenmyer, president
Mary Shultz, vice-president
Pat Shippey, treasurer
Jerry Hughson, secretary
John Rogers, member
Dave Rodgers, member
Greg Burkes, member
Linda Rudd, member
Gregg Hoffman, member
Stephanie Wood, Association Manager
Diana Peters (DC)

Absent: None

Property owners present: Coach and Patti Abshire,
Marc Bell

Approval of Minutes: Minutes were previously distributed to all board members. There being no additions or corrections, the minutes of the March 16, 2015 board meeting stand approved as written.

Property Owner Comments: None

Reports and motions:

President Larry Wittenmyer reported to the board items from his quarterly meeting with the Development Company. Expansion of the Reserve Club will commence soon, with 99 new parking spots to be added.

President Larry presented to the board the offer from the S.C. DOT for two small "slivers" of land (.189 acre) required to commence the widening of Silver Bluff Rd. The offer from the DOT was \$24,500, which was accepted by the board.

Treasurer Pat Shippey reported only 41 delinquent accounts for annual assessments equating to 1.9%, which is very low. Expenses for March were nominal.

Greg Burkes (Communications and Technology) made a motion to enter into a contract with "Alive Media" to design, program, and setup the new WPPOA web site, which will include a "resident only" area requiring password to access. Linda Rudd seconded the motion, which subsequently passed.

Dave Rodgers stated that, because of the extensive tornado damage, tree removal requests for removing storm damaged trees will be suspended for two weeks, and residents may put trees and branches out early. The Association Manager will send a mass E-Mail to residents.

Mary Shultz (Landscaping) reported on damage from the tornadoes and plans have already begun to begin cleanup on common areas.

Diana Peters (Development Company) reported that Kisner Construction is a new authorized builder for phases IV areas. Kisner Construction will be associated with Carolina Signature Homes.

The board received verbal reports from all directors. Important information will be communicated to residents in the WPPOA Newsletter.

The meeting was adjourned at 4:29PM

Respectfully submitted,

Jerry Hughson, Secretary

ARB**Dave Rodgers****Help Us Help You This Project Season**

Spring is always a busy time in Woodside as we enjoy the warmer weather and start watching our wonderful landscaping come to life again. As I'm writing this newsletter, I'm sitting on our deck in the sun with dirt under my fingernails from planting some new Azaleas – it was a tough winter on a few of them. As I was planting I noticed that our neighbors had some stone steps at the back of their yard and I thought something similar would look great in ours. And that means I have to put a project request into the ARB and wait for approval before starting.

Woodside is the first community we've lived in with an ARB Office to review homeowner modifications to the exterior of their homes or landscapes and it has taken a little bit to get used to it. But it didn't take long to appreciate it! The ARB exists to review proposed building, remodeling and/or alteration activity, and to encourage quality design and characteristics that will maintain and complement the natural beauty and attractiveness of our community. No small task! Spring is a busy review time at the ARB office and the current ARB Board, comprised of an elected Director and five resident volunteers, do their best to review and approve your plan requests as quickly as possible so not to delay the start of projects.

So, what can you do to help us help you get through the approval process?

The ARB meets on the 2nd and 4th Monday of each month and you should try to have your requests into the office one week before the meetings. The staff will look them over and identify if there are outstanding items prior to Board review.

When you pick up your request forms, ask the staff what really needs to be included for review. If during review, the Board cannot understand the project or you haven't provided required data, it will need to be submitted again and will cause an unnecessary delay.

Review Section 2 and subsection 2.2 of the Building Guidelines (they are on our website) to better understand what you need to do when submitting a request.

Determine if colors, finishes, set back information, site plans, or material samples are required and supply them.

If your project is truly involved or complex, please invite yourself to the meeting so that you can address questions in person and help the Board help you move forward with your project.

Have a wonderful Spring in Woodside and good luck with your projects!

PS: Makes me proud to say I live in Woodside after seeing how everyone pitched in to help each other and clean up after the tornados!!

**NO
OVERNIGHT
PARKING**

Overnight parking is a violation of safety code and the Covenants & Restrictions of Woodside. Please note that Overnight parking is NOT allowed. You will be ticketed and the information will be turned into the POA office. After numerous incidents, you will receive a letter as a warning. Repeat offenses will be subjected to a fine and/or towing as directed in the Covenants. Having streets clear will enable us to have all Woodside roadways open for emergency vehicles throughout the night.

LAKES AND DAMS

I am pleased to report that the French drains on Holley, Burden, Royal, and Magnolia Lakes have been successfully cleaned by our vendor, the "Drain Surgeon" (isn't that catchy?) from Augusta, GA. A 3,000 psi "sewer jet" device was used in each drain, followed by a camera inserted to check the line. This completes another recommendation by Schnabel Engineering in their report from last year. There are only two other minor items to accomplish from their report.

Following is the report from Granite Ridge Aquatic Services for April. GRAS is now visiting Woodside twice a month for the summer.

April 22

1. Treated Holley Lake for floating hearts and other noxious aquatic weeds and algae.
2. Treated Burden Lake for floating hearts and water primrose.
3. Added dye to Winged Elm.
4. Checked Magnolia Lake - needs to be sprayed next visit.
5. Royal Lake beginning to show some algae and alligator weed.

May 2

1. Treated Royal Lake for algae and alligator weed around the perimeter.
2. Added more dye to Winged Elm.
3. Checked to see how effective our last treatment of Holley Lake was - positive results.
4. Checked Burden Lake to see how effective the last treatment was - positive results.
5. Magnolia Lake was to be treated, but swirling winds made it too risky.

End of GRAS report

See you next month!

Jerry

Jerry Hughson

FISHING NEWS

POSSIBLY THE GREATEST FISHING PHOTO OF ALL TIME



Anyone that reads my monthly input on Fishing to the POA Newsletter knows that last month I described how 7 year old Benjamin Garrison out fished 15 other young anglers to capture the \$100 Ben Franklin that goes to the 16 and under angler that catches the longest bass at

Woodside's Spring and Fall Fishing Outings. The story is special because Benjamin did it with a "CARS" movie plastic fishing rod and reel. That's a great story, BUT it is better told by the photo of Benjamin that was taken by Jack Royalty after he received his prize. NOW, that is a fishing photo. While your eyes are drawn to the Ben Franklin, the smile and joy on the face of a 7 year old very quickly takes over the photo. And, finally the Superman muscle shirt makes it very clear that this young man was in charge of the Spring outing. I'm jealous of Jack Royalty's ability to capture this great photo. If I had the camera, it would have been a standard fishing photo of Benjamin holding his fish with his arm extended far forward to make the fish look larger in the camera. When Benjamin is grown and has his own family, I hope he has this photo framed in his house.

With respect to the current state of fishing on our lakes, it is absolutely fantastic. A large number of bass are being caught however no one has surpassed Keith Crawley's 20 inch bass in the Big Bass competition. With respect to Colossal Crappie, my brother, Tony, has entered a 14 1/8 inch crappie and currently holds the lead. He caught the crappie on a minnow fishing on Holley Lake on April 13. While I love my brother, I have been taking out other fishermen in the hope of toppling him from the lead.

If you would like to schedule a KIDS FISHING OUTING, please contact Frank Shallow or myself. We already have some dates reserved in May and June.

Ken Ziomek
803-649-9842
ziomekk@bellsouth.net

TREASURER'S REPORT

Pat Shippey

In early May the delinquent accounts had an outstanding balance of \$21,063, excluding late fees. At this time last year the outstanding balance was \$13,067. All assessments must be paid by May 29th in order for you to renew vehicle decals and keep barcodes activated. All delinquent accounts continue to accrue monthly late fees and after May 31st a barcode reactivation fee will also be added. The list of unpaid accounts as of June 1st will be published in the June newsletter and will also be forwarded to our attorney to begin the lien process.

Working Capital fees were received from the sale of six lots that closed in April. Our ordinary expenses through April were under budget.

So far we have spent \$7,500 for clean-up as a result of the tornados that touched down in the Juniper Loop and Boxwood areas. The high winds uprooted trees in other areas of the Plantation and there was some minor damage to our perimeter fencing.

COVENANTS

Linda Rudd

With this beautiful spring weather the complaints and concerns about yard care and maintenance have greatly increased. Some concerns about the condition of yards are just a matter of taste but most are based on the home owner just not keeping their yard or lots mowed, trimmed and looking cared for. This time of year, the grass grows faster and needs more frequent mowing. Rental property and vacant homes are still the responsibility of the property owner and when the POA receives complaints, we contact the owner of record requesting they do the required maintenance. In cases where the proper maintenance is not taken care of, we can have it done and bill the property owner. In addition, pots or yard ornaments in a front yard must be part of a good yard design and statues that are over three feet in height need approval from the ARB. If you have a question about your design and additions to your yard, call the POA and find out. A well maintained and designed yard adds to the value of the neighborhood and community but a yard or lot that is overgrown or not kept up detracts from the overall appearance we all want in our neighborhood. Let us know if we can help.

DEVELOPMENT COMPANY

Diana Peters

Steve Kisner Joins Carolina Signature Homes



Carolina Signature Homes is pleased to announce that Steve Kisner has joined its team of quality homebuilders to form a new custom home division – Carolina Signature Homes by Steve Kisner. Steve has built over 250 beautifully created and quality constructed homes in Aiken County over the last 25 years, many of them in Woodside Plantation. He is a Certified Green Builder and was Voted Best Home Builder in 2013 and 2014 by the readers of Aiken Standard. Steve's first showcase home in The Reserve will be underway soon adjacent to Woodside's newest park, the beautiful Summer Hill Park.

Many Woodside residents know Steve and his family – his wife, Christy and 3 children – so, when you see Steve, please say 'hello' and congratulate him on his new affiliation with Carolina Signature Homes!

ARB Activity February, 2015

- Building and Environmental Inspections – 27
- Homeowner issues - 8
- Improvements – 22
- Landscape Plans – 14
- Policy Development - 1
- Satellite Dish Location Requests - 3
- Tree Removal Requests – 27
- Variance - 2



SUMMARY OF COMPLAINTS
April, 2015

- Neighbor – Neighbor - 1
- Pet - 1
- Referred – 8
- Trash Receptacles - 1
- Unsightly Conditions – 8
- Yard Debris - 1

Total Complaints - 20

Referred Complaints

- Common Area – 1
- Lakes & Dams - 1
- Roads – 3
- Security – 1

Total Referred Complaints - 8

NOMINATING COMMITTEE

The Woodside Plantation Property Owners Association (WPPOA) Board of Directors will have three positions open for the upcoming election at our Annual meeting in September 2015.

The nominating committee is actively pursuing leads in our recruiting effort to find residents of Woodside to run for these three positions. But we need YOUR help. If you would like to learn how your POA operates, and to be involved in management of the community, please consider running this year.

The Nominating Committee members, in addition to me, are Mary Shultz, Ken Blohm, and Linda Walters. If you think you might be interested, please contact any one of us on the Committee, either by telephone (our numbers are in the directory), or send an E-Mail to WPPOA@WPPOA.com and ask that your E-Mail be forwarded to us. If you would like to come by and attend a Board meeting for information, we meet on the third Monday of each Month in the conference room of the POA office. I encourage you to step up and get involved in the leadership of Woodside!

Linda Rudd

2015 Nominating Committee Chair





WOODSIDE PLANTATION

1411 Silver Bluff Road
Aiken, SC 29803

Phone: 803.641.9663
Fax: 803.641.1831
Email: wpboa@wpboa.com
www.wpboa.com

WPPOA OFFICE

Stephanie Wood, Association Manager
June Carlson Keena Adams
Trisha Leveille Wayne Brock
Michelle Yonce George Hughes
Dave Prough

WPPOA BOARD OF DIRECTORS

PRESIDENT
Larry Wittenmyer

VICE-PRESIDENT & COMMON AREA LANDSCAPING
Mary Shultz

SECRETARY, LAKES & DAMS
Jerry Hughson

TREASURER
Pat Shippey

SECURITY
Greg Hoffman

COVENANTS
Linda Rudd

ROADWAYS, STREET LIGHTS/ SIGNS, WALKING PATHS
John Rogers

ARB
Dave Rodgers

TECHNOLOGY, COMMUNICATIONS, FACILITIES AND AMENITIES
Greg Burkes

Welcome To Our New Residents

Michael & Heather Pisano
158 Highland Reserve Court
Moved from Clinton, NJ

Joseph & Suzanne Elseman
304 Huntington Court
Moved from North Augusta, SC

David & Carolyn Crabb
193 Bellewood Road
Moved from Indiana

Nevin & Janet Gilbert
120 Sweet Gum Lane
Moved from Aiken, SC

Rodney & Kay Hawk
129 Glen Haven Circle
Moved from Savannah, GA

Nita Martin
213 Hackberry Lane

Ashley Toole
407 Forest Ridge Drive

Rick & Martha Funk
209 Birch Tree Circle
Moved from Ohio

Michael & Mary Ann Wennemer
157 Pinyon Pine Loop



Kennedy Business Services, Inc.

An IRS Registered Tax Return Preparer

- ◆ Tax Preparation /Authorized IRS e-file provider
- ◆ Accounting services and payroll preparation
- ◆ Providing personalized service to clients since 1991
- ◆ Consultations at your convenience - in your home or our office
- ◆ Member: National Association of Tax Professionals

Robert P. Kennedy
 157 Balsam Lane
 (803) 649-3308
 rpkenedy29803@yahoo.com



Aiken Pet Sitters
 At-home Pet Care in Aiken SC

June Crawford
 (803) 648-4599
 www.aikenpetsitters.com
 info@aikenpetsitters.com
 Reliable * Experienced * Insured * Bonded



Genny Fansmith
 Realtor
 Cell or Text:
 803-617-8039
 email:
 gfansmith@aol.com

The Fansmith Team

Meybohm

REALTORS®

1070 Silver Bluff Road
 Aiken, SC 29803

Direct:
 803-644-1739
 Fax:
 803-649-7897
 Toll Free
 800-868-5625 x 739



George Fansmith
 Realtor
 Cell or Text:
 803-617-8038
 email:
 gjfansmith@aol.com

LEN JOHNSON
 Cell: 803 439 5201
FREE ESTIMATES

SPECIALIZING IN :
 CARPET, UPHOLSTERY, & WINDOW CLEANING

Gonzalez Landscaping
 Self employed!
Jesus Gonzalez
 Residential & Commercial

Mowing, edging, weed eating, tree & shrub pruning, tree cutting, mulching flower beds, pinestraw, and much more.

For an estimate call:
 (803)646-0093 or
 (803)392-0519

By agreeing to display business ads, the WPPOA is not endorsing or recommending the use of any advertiser. The decision on which businesses to use is left entirely to the homeowners. To place an ad, call Woodside Property Owners' Association 641-9663, and ask for Keena Adams or email keena@wppoa.com

Advertising prices per month: Business Card \$35, Quarter Page \$55 and Half Page \$85.

May2015.

Margaret's Garden

ADULT DAYCARE

"WE MEET YOU WHERE YOU ARE"

119 Beatty Lane – Aiken, South Carolina 29803

Specializing in offering care to meet the needs of the whole individual

Physical – Mental – Social Stimulation

"Come Experience our Fine Dining Atmosphere"

Full Day and Half Day Services Available – No Contracts

PHONE 803-226-0099 • www.margaretsgardenadultdaycare.com

Dorean Price, RN • Owner/Operator • dprice@atlanticbbn.net

Just minutes from Woodside



803-648-9535

Resort Amenities • Lovely Golf Views • Peaceful Location

897 Houndslake Drive
Aiken, SC 29803

theinnathoundslake.com
stay@theinnathoundslake.com



KIRK ROBERSON
34 YEARS OF EXPERIENCE
RESIDENTIAL AND COMMERCIAL

407 Sugarcreek Drive
Grovetown, Ga. 30813

803-502-4347 cell
706-210-4365 lv msg.

**Exterior/Interior
Painting and
Restoration**

803-502-4347

407 Sugarcreek Dr.
Grovetown, GA 30913

Serving customers in
SC and GA



Aiken County
Habitat for Humanity
ReStore
1026 PARK AVE. SE. AIKEN, SC
803-642-0530

HABITAT FOR HUMANITY-AIKEN

Join Habitat in reaching families in need of decent housing. Donate unneeded furniture & household items!
Call Us! 803-642-0530 We Pick Up!

Store Hours: Tuesday-Friday 10am-4pm | Saturday 10am-1pm

Pressure Washing & Window Cleaning!

803-439-1867

- ✓ Driveways
- ✓ Gutter Brightening
- ✓ Low Pressure Siding Cleaning
- ✓ Roof Stain Removal
- ✓ Window Cleaning



Woodside Resident
Licensed & Insured



www.AikenSoftWash.com

Pressure Washing & Low-Pressure Exterior Cleaning

By agreeing to display business ads, the WPPOA is not endorsing or recommending the use of any advertiser. The decision on which businesses to use is left entirely to the homeowners. To place an ad, call Woodside Property Owners' Association 641-9663, and ask for Keena Adams or email keena@wppoa.com

Advertising prices per month: Business Card \$35, Quarter Page \$55 and Half Page \$85.

May 2015.

Is your A/C system ready for warmer weather?



It's time to change your filters and have your A/C system cleaned. We'll keep your HVAC system running smoothly and at peak efficiency — and that can even save you money with **lower utility bills**. Our **Maintenance Service Programs** can even help extend the life of your system and our award-winning service is here for you **24/7, 365 DAYS A YEAR!**

MAINTENANCE SERVICE PROGRAM INCLUDES:

- ✓ Priority Scheduling
- ✓ No Overtime Charges
- ✓ 15% Off Repairs

Call the Service Experts at

HOLLEY

Heating and Air Conditioning, Inc.

A name you know. A name you trust.

Call today. (803) 649-6551

Emergency Service 24/7/365 Days a Year

Visit us on the web at holleyheatingandair.com



Need a New A/C System?



Get up to **\$1900 CASH BACK** on a new high-efficiency Carrier® system. Call **803-649-6551** for qualifying products and rebate details.

*Maximum combined totals from Carrier and SCE&G rebates. Offer good until 05/31/2015.



SPORTS PLUS

Physical Therapy

**Convenient
Woodside
Location!**

right now!

Immediate Attention. Unmatched Compassion. Amazing Skills.

- Joint Sprains & Strains
- Neck & Back Pain
- Orthopaedic Injury Rehab
- Sports Injury Rehab
- Return to Golf Program
- Post-Operative Treatment
- Total Joint Replacement Rehab
- Injured Worker Rehab
- Auto Accident Injury Treatment



1397 Silver Bluff Road
Aiken, SC 29803
P 803.220.1073
www.csmr.org

WOODSIDE PROPERTY OWNERS' CLASSIFIED ADS

There is no time like the present to start thinking about the future.



The Wealthcare Difference:

- ✓ Stress-free approach
- ✓ Fee-only financial planning
- ✓ We do not accept commissions from the sale of insurance, investments, or any other products
- ✓ Long-term strategies for financial growth
- ✓ Objective, conflict-free advice that has your best interests in mind

WEALTHCARE
FINANCIAL PLANNERS

Call today for a free, no-obligation consultation!
(803) 644-0701



WILLIAM J. COSCIONI
CPA, CFP, President

ASIS-WNSP2607

910 Dougherty Road, Aiken, SC 29803 | www.wealthcare910.com



Dalzell Design Landscaping, Inc.

Landscape Design/Build, Land Planning, and Consulting

Will Dalzell (706) 825-4572

175 Sweetwater Rd. North Augusta, SC 29860

www.dalzelldesignlandscaping.com

Affordable **PRESSURE WASHING**

Driveways • Houses • Pools

Jim Beasley
AffordablePW@yahoo.com

Licensed and Insured
803-292-1775

Harris
Lawncare
& Landscaping, LLC



706-830-0708
www.Harris-Landscaping.com

Sensible Solutions

House Cleaning

*Pet Care *Errands *House Sitting
Kerri Creamer 803 507-1492

Professional Service
Reasonable Rates

David Buchanan
(803) 507-2296 Aiken
(706) 755-3978 Augusta
aikenaugustahousewash.com

ROOFS • DECKS • GUTTERS • CONCRETE • HOUSE WASHING

AIKEN AUGUSTA
HOUSE WASH



Free Estimates

C & R Tree & Stump Service
Licensed & Insured

CASEY RICHARDSON
(803) 439-6315

By agreeing to display business ads, the WPPPOA is not endorsing or recommending the use of any advertiser. The decision on which businesses to use is left entirely to the homeowners. To place an ad, call Woodside Property Owners' Association 641-9663, and ask for Keena Adams or email keena@wpppoa.com

Advertising prices per month: Business Card \$35, Quarter Page \$55 and Half Page \$85.

May 2015.

WOODSIDE PROPERTY OWNERS' CLASSIFIED ADS



The POA is searching for Board Candidates for the Fall Elections. If you are interested, please call the POA office or Linda Rudd.



Andrew Reynolds
ISA Certified Arborist
(706) 819-0683
areynolds@arborequityinc.com
www.arborequityinc.com

- Tree and Shrub Pruning
- Plant Healthcare
- Deep Root Fertilization
- Tree Removal
- Deer Repellent Plant Treatments
- Ask about our other services



Specializing in Interior Renovation

Free Estimates & Reasonable Rates!

Licensed • Bonded • Insured

Primary: 803-640-4069

Office: 803-593-8317



*Evergreen Irrigation, Landscaping
and Lawn Care*

Residential • Commercial

FREE ESTIMATES • SATISFACTION GUARANTEED

Owned and Operated by

CHRIS & DAWN BEAM

(803) 645-7757

Howell Printing COMPANY Since 1867

Located in beautiful downtown Aiken

345 Barnwell Ave, NW

803-649-2545

www.howellprinting.net

We are a locally owned business that offers quality craftsmanship with personal service and will go the extra distance to ensure the highest quality printing.

- Booklets
- Cards
- Banners
- Brochures
- Posters
- Large format

One-stop shop for printing, design, mailing, marketing projects and much more.



NERIUM's Innovative Anti-Aging Products

Love your skin. Reflect your youth.



The results of Nerium's products speak for themselves.

Look Younger!

You will see & feel the difference in just one week....

Call 803-648-5498

*TRY this revolutionary product!
www.djeancarter.nerium.com*

WOODSIDE PROPERTY OWNERS' CLASSIFIED ADS

Patio, Sunroom, Poolside
We're Your
Relaxed Living Headquarters!

Outdoor/Sunroom Furniture
All-weather wicker
- Hammocks
- Tropical Furnishings,
Wall Art including fun signs
to hang poolside or barside



Polywood Furniture
exclusive Aiken-Augusta dealer

- Won't rot, splinter or crack - completely weatherproof
- Easy to clean material has solid color throughout
- Substantial and durable outdoor furniture, 20 yr limited warranty

We Also Carry Fire Pits And Grills.



WICKER BARN

706.364.3570
wickerbarn.com
3910 Washington Rd, Augusta
(just West of Bobby Jones Expwy)

Trusted Service Since 1967

- Protecting Your Health & Property for Over 47 Years
- Home, Business, and Industry
- Environmentally Responsible

Call Now!
803-649-9803
www.aikenpest.com



All Saints' Anglican Church

Corner of Fairfield St. & Richland Ave.

Dignity of Worship - Tradition - Family
Steadfast Faith - Conservative Values

Services

Sunday: 8:30 a.m. & 10:30 a.m.

Wednesday: 5:30 p.m.

Tel: 803-648-9991 Website: allsaintsaiken.org

TurfArtistry

Locally Owned and Operated

Call Today!

For Your **FREE** No-Obligation Lawn Evaluation
(803) 522-4668

\$30 First Weed Control Visit

*Lawns up to 5000 sq ft

Services Offered

Fertilization-Weed Control-Lawn Insect control-Lawn Disease Control-Core Aeration-Lime-Tree & Shrub Fertilization, Insect Control and Disease Control

www.turfartistry.com

803.643.2772
Aiken

Al Duffie
owner

compufix
on site service for your computer needs

keeping the connection to your world working

www.compufix1995.com

serving Aiken since 1995

By agreeing to display business ads, the WPPOA is not endorsing or recommending the use of any advertiser. The decision on which businesses to use is left entirely to the homeowners. To place an ad, call Woodside Property Owners' Association 641-9663, and ask for Keena Adams or email keena@wppoa.com

Advertising prices per month: Business Card \$35, Quarter Page \$55 and Half Page \$85.

May 2015.

WOODSIDE PROPERTY OWNERS' CLASSIFIED ADS



Pat Roberts
 Realtor
 803-270-1730
 pat@aikensc.com
Selling Aiken for Over 30 Years
 View My Virtual Tours at-
 www.aikensc.com

Woodside Plantation continues to be in demand. Whether buying or selling, please give me a call for all of your real estate needs.







Kim Burke
Stylist/Color Specialist
 864-918-4077
Town Creek Salon and Spa
 101 Town Creek Rd, Aiken, SC, 29803



kendrickbodyshop.com

513 Silver Bluff Rd. | 3720 Richland Ave. W.
 Aiken, SC 29803 | Aiken, SC 29801
 803.617.0324 | 803.649.2676

Aiken's A Team



CALL US AT (803) 292-6779





AIKEN'S SPECIAL FORCE
 In Residential and Commercial Real Estate

www.aikenteamrealty.com

If you, your family or friends need help buying or selling real estate, call the A Team or visit our website which showcases our Aiken Community.

Wally Busch 803-640-7978
 Joe Murphy 803-292-6779
 Mike Calhoun 803-292-4449





By agreeing to display business ads, the WPPOA is not endorsing or recommending the use of any advertiser. The decision on which businesses to use is left entirely to the homeowners. To place an ad, call Woodside Property Owners' Association 641-9663, and ask for Keena Adams or email keena@wppoa.com

Advertising prices per month: Business Card \$35, Quarter Page \$55 and Half Page \$85.

Andrew St.Clair



Home Renovation Specialist

803 221-6709

One Call Does It All

Bathrooms+kitchens+tilework+painting+flooring
19 years servicing fine northern homes

Now a Woodside resident

Knowledgeable-Dependable-Reputable

A. QUINN TREE EXPERTS

FREE
ESTIMATES

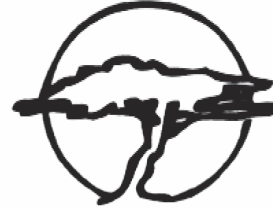

- * DANGEROUS TREE REMOVAL
- * CERTIFIED ARBORIST
- * STUMP REMOVAL
- * 40 YEARS EXPERIENCE
- * FULLY INSURED
- * LOCAL REFERENCES AVAILABLE

SENIOR CITIZENS
DISCOUNTS

803-295-2051
770-256-0128

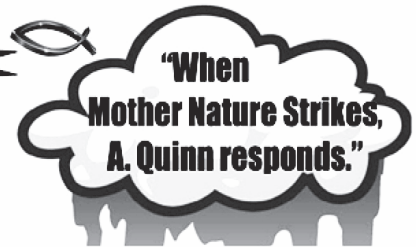

MAGNOLIA CHAUFFEUR & LIVERY



Personal service, flat fee pricing, easy online booking

Aiken's best airport service

Flexible hourly and evening service

Affordable point to point transfers

803 220 4600



800 624 1622

www.magnolialivery.com

Aging into Medicare? Shop locally...with Ruby!



- ◆ Offering all major Medicare Supplement Carriers
- ◆ Specializing in Senior Products: Long Term Care, Final Expense, Drug Plans & Medicare Advantage
- ◆ Efficient, confidential and professional
- ◆ Local service!!!

Ruby Masters
803-349-7468

Mark Taylor and Associates, LLC
965 Dougherty Road, SW, Aiken, SC

WOODSIDE PROPERTY OWNERS' CLASSIFIED ADS

186 Foxhound Run \$479,873

437 Spalding Lake Circle \$284,500

Build your dream home!



*Choose a spectacular lot
from the ones below:*

140 White Cedar Way \$49,900

123 Longwood Green \$34,000

178 Mockernut \$104,900

337 Huntington Court \$24,500



GOLF-COURSE LOT!



CHARMING STREET!



ON THE WATER!



SPECIALLY-PRICED LOT!

Hurry Home to Woodside



Exceptional homes and lots are waiting in Woodside! If you know of anyone who is longing to hurry home, tell them about these lovely opportunities.

Nancy Cerra, REALTOR®
(803) 295-3424
nancy@nancycerra.com

Meybohm
REALTORS®

Aiken's Golf
Community Specialist

green
NAR's sustainable property designation

Nancy Cerra
Hurry home.™



**HITCHCOCK
HARDWOOD**

HARDWOOD FLOORS AND STAIRS

INSTALL - REFINISH - REPAIR - DEEP CLEAN

WE SPECIALIZE IN OCCUPIED HOMES

DUST FREE

DURABLE LOW ODOR FINISHES

DRY TO WALK ON IN 3 HOURS

NO NEED TO LEAVE YOUR HOME

**CALL FOR A FREE ESTIMATE
803-648-7255**

www.HitchcockHardwood.com



At
**Burns
Dance
Studio**
831 Neilson Street

Monday, Wednesday, Friday

8:30-9:30a - Zumba Basic

9:45-10:30a - Zumba Gold

One Class - \$5 Ten Classes - \$40
Students - \$3



Instructor - Bobbie Farmer

bobbiefarmer.zumba.com

bobbie5115@aol.com

'EXERCISE IN DISGUISE'

By agreeing to display business ads, the WPPPOA is not endorsing or recommending the use of any advertiser. The decision on which businesses to use is left entirely to the homeowners. To place an ad, call Woodside Property Owners' Association 641-9663, and ask for Keena Adams or email keena@wppoa.com

Advertising prices per month: Business Card \$35, Quarter Page \$55 and Half Page \$85.

May 2015.

WOODSIDE PROPERTY OWNERS' CLASSIFIED ADS

Remodeling~Room Additions~Renovations



Complimentary In Home Consultation

Call the Woodside Experts



Aiken Design Center
at The Village

230 Village Green Boulevard
Aiken, SC 29803
803.617.0919



**FIRST CHOICE
PAINTING INC.**
Licensed • Bonded • Insured
www.firstchoicepainting.com



Phone
(803) 644-3318

Owner
QUINCY HOCHSTETLER

RETURN ENGAGEMENT

Upscale ladies consignment

Located in the Historic Holley Building—
Downtown Aiken
Free Concierge home visits for estates and large consignments

Hours: 10:30am-5:30pm 803-642-3337
113 Laurens St SW Open consignment on
Suite 106 Aiken, SC Mondays. By Appt T-Sa

www.Returnengagementaiken.com

FUSION CAPITAL

*Aiken * Charleston * Myrtle Beach*



Comprehensive Wealth Management & Financial Planning

Jason M. Mengel, CFP® & Dan Webster, RFC®

821 Richland Ave. W
(803) 644-1214

www.fusioncapital.net



By agreeing to display business ads, the WPPPOA is not endorsing or recommending the use of any advertiser. The decision on which businesses to use is left entirely to the homeowners. To place an ad, call Woodside Property Owners' Association 641-9663, and ask for Keena Adams or email keena@wppoa.com
Advertising prices per month: Business Card \$35, Quarter Page \$55 and Half Page \$85.

May 2015.



Sunshine

Hand Window Cleaning
Roof Stain Removal
Gutter Cleaning
Deck Restoration
Concrete Cleaning

Pressure Washing & Window Cleaning
 O: (803) 642-6341 • F: (803) 641-0169
 Brent & Brad Chavis

Proudly Serving Woodside for over 15 Years!

Take charge of your dream for a confident retirement.

Call me today at 803.641.2192 to get started.



Michael P. Griffin, CFS®, CDFP™
Financial Advisor
Business Financial Advisor
152 Laurens Street NW
Aiken, SC 29801
michael.p.griffin@ampf.com
ameripriseadvisors.com/michael.p.griffin



Ameriprise Financial Services, Inc. Member FINRA and SIPC.
© 2014 Ameriprise Financial, Inc. All rights reserved.

Carolina Porch Designs

Specializing in...

- All-Season Rooms • Florida Rooms
- Screen Rooms • Decks

Gene Wengerd
(803) 507-4280

Licensed General Contractor - Bonded



NO-FRILLS
Painting

Free Estimates • Reasonable Rates
Licensed & Bonded

Joseph Nirenberg
Owner

Mobile: (803) 295-1104
nofrills@comcast.net

WOODSIDE PROPERTY OWNERS' CLASSIFIED ADS



**The
G.R.A.S.S.
Company, LLC**
(Great Rates Always Superior Service)

RICK FOWLER | Owner/Operator
(803) 221-7597 | richardgfowler@bellsouth.net
Total Landscaping & Lawn Care

K & G Painting
Aiken, SC

Licensed - Bonded - Insured
Residential & Commercial Painting
Free Estimates • Work Guaranteed
Complete Deck Services
Professionalism not to be compromised
Honest people you can trust

803-502-0262 • 803-474-2546
dvdloc@aol.com

Ron's Home Repair Service
(No Job Too Small)
803-642-9344

home repairs	deck staining
painting	shelving
power washing	wall papering
epoxy floor coating	lights & fans

Ron Tugya Woodside Resident

Adam's Nursery and Landscaping
"Strong Roots--Steady Growth"



Landscape Design and Installation
Lawn Maintenance
Irrigation Installation or Repairs
One Time Clean ups
Backhoe Work

(803) 259-2538
(803) 300-0896
(803) 259-2326 Fax

adamsnursery.net

210 Curtis Drive Williston SC 29853
adama29853@yahoo.com



**Everett Johnson Roofing
and Construction Co., Inc.**

318 Croft Mill Rd.
Residential and Commercial Roofing
RHETT JOHNSON
Licensed and Insured
Office 803-641-2365 • Fax 803-641-1503
Mobile 803-645-2804 • Email TEJRoofing@aol.com

Jason K. Crane
Financial Advisor

Edward Jones
MAKING SENSE OF INVESTING



772 Silver Bluff Rd
Aiken, SC 29803
Bus. 803-649-5134
Fax 866-462-7719
jason.crane@edwardjones.com
www.edwardjones.com

Call today!
(803) 226-0380



Spring-Green Lawn Care
Your local lawn and tree care professionals.
Joe Ferrari, Owner • jferrari@spring-green.net
(803) 226-0380 • www.spring-green.com



**Fur Kidz Pet
Sitting**

Shirley Wisz
owner

(803) 648-9068 Home
(630) 673-4817 Cell
"I will treat them like my own"
Specializing In Daily, Midday, &
Overnight Pet Care

By agreeing to display business ads, the WPPPOA is not endorsing or recommending the use of any advertiser. The decision on which businesses to use is left entirely to the homeowners. To place an ad, call Woodside Property Owners' Association 641-9663, and ask for Keena Adams or email keena@wpppoa.com

Advertising prices per month: Business Card \$35, Quarter Page \$55 and Half Page \$85.

WOODSIDE PROPERTY OWNERS CLASSIFIED ADS

"I would like to receive more information and advice on how to achieve my retirement goals."



Call (803)649-6645 to speak with a professional financial advisor.

149 Crepe Myrtle Ct. Aiken SC 29803
www.tsgwealth.com
~ locally owned & operated ~



The Smith Group
Tax & Wealth Advisors

Financial Planning and Investment Advisory Services are offered through C2P Capital Advisory Groups LLC D/B/A Prosperity Capital Advisors (PCA) an SEC registered investment adviser with its principal place of business in the State of Ohio. For more information regarding PCA please visit www.adviserinfo.sec.gov. PCA does not offer tax and/or legal advice.



Conference and Meeting Rooms

- Private Executive Day Office
- Virtual Office Solutions
- Mail Box Solutions

www.Citizensparkocc.com

803.226.0504

Your Mobile Office Solution



2152 Silver Bluff Road
Aiken, SC 29803

- Siding & Fencing
- Custom Kitchens & Bathrooms
- Room Additions/Carports
- Custom Decks & Porches
- Seamless Gutters

Herbert "Skip" Wright, Jr.
644-3006

Mobile 215-3671
www.wrightshomeimp.com



PAUL WRIGHT
owner

O- 803-644-3006
C- 803-221-5374

Free Delivery with 20 Bale Order!
e-mail: pinestrawbypaul@yahoo.com
2152 Silverbluff Road
Aiken, SC 29803

"Your Yard is Our Priority!"

**Long Leaf Pinestraw - Lawn Maintenance -
Landscaping - Tractor Work**

By agreeing to display business ads, the WPPPOA is not endorsing or recommending the use of any advertiser. The decision on which businesses to use is left entirely to the homeowners. To place an ad, call Woodside Property Owners' Association 641-9663, and ask for Keena Adams or email keena@wppoa.com

Advertising prices per month: Business Card \$35, Quarter Page \$55 and Half Page \$85.

May 2015.

WOODSIDE PROPERTY OWNERS' CLASSIFIED ADS

Owned and Operated by
longtime Aiken residents
Wanda (born in Naples),
Cliff & Kirstyn

803 226-0700



Apizza di Napoli

Authentic Neapolitan Wood-Fired Pizzeria
740 Silver Bluff Rd. Aiken, SC 29803

www.apizzadinapoli.com or www.facebook.com/PizzaDiNapoli

Our Pizzaiolos' are Certified by the Verace Pizza Napoletana.
The Italian governing body for quality designations in
making true Italian foods. Only VPN Pizzeria in NC, SC & GA



Hawkins

Irrigation & Repair

Licensed, Bonded & Insured
Free Estimates

Jeff Hawkins, Owner
803.292.5380

- Residential
- Commercial
- Installations
- Modifications
- Repairs



CRUISEONESM
Dream Vacations Start Here

Discover the CruiseOne Difference
Personal Service and the Lowest Price

Why Book Your Next Cruise or Resort
Vacation with **Me?**

Excellent customer service
on all travel purchases.

Unbiased advice to find the
best vacation for you.

Exclusive pricing and promotions.

Joe Mesimer & Ingrid Graves

INDEPENDENT VACATION SPECIALISTS

Aiken, SC

(803) 649-4108

(888) 805-7447

www.cruiseone.com/jmesimer

CA 2006278-40, FLST 35829, IA 655, WA 601698664, NV 2005-0073. © CruiseOne

School's
out for
Summer



Have a safe
Summer Vacation!



By agreeing to display business ads, the WPPPOA is not endorsing or recommending the use of any advertiser. The decision on which businesses to use is left entirely to the homeowners. To place an ad, call Woodside Property Owners' Association 641-9663, and ask for Keena Adams or email keena@wppoa.com

Advertising prices per month: Business Card \$35, Quarter Page \$55 and Half Page \$85.

May 2015.



Tree Removals
Stump Grinding
Landscaping



Free Local Estimates
Sell Fire Wood

Quality Tree Service Inc.

Residential, Commercial
Licensed, Bonded, Insured
803-663-3278

Owner
Tim George 441-3322 Pg
Cell 803-979-6800

Mailing Address:
128 Pine Hollow Dr.
Aiken, SC 29803

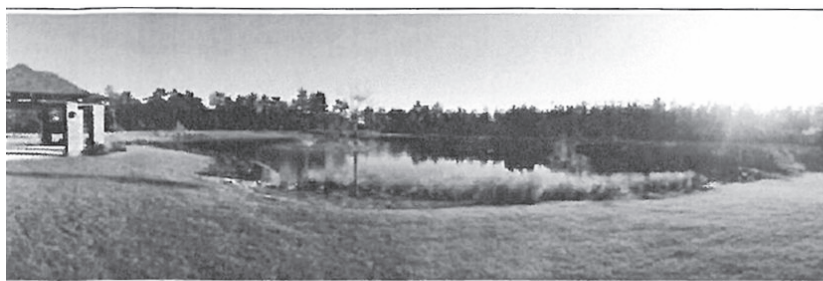

The C.A.M. COMPANY 803-522-4028

- * Superior Lawn Care Practices
- * Prunning, mowing , edging, blowing
- * Irrigation repair and service
- * Pinestraw, mulch applications

Proudly serving...
Woodside Plantation
& The Village at Woodside

30+ years of combined service
in Woodside Plantation.

Courteous & Professional Staff!

On-Time, Reliable Service!

*Bryan Sweetnam
Manager*

*Shawn Eigel
Asst. Manager*

Enjoy Your Home

**ROOF REPAIR &
ROOF REPLACEMENT**

**KITCHEN &
BATH REMODELS**

**WINDOW & DOOR
REPLACEMENT**

**SUNROOMS &
ROOM ADDITIONS**

**ATTIC & BASEMENT
CONVERSIONS**

AND MORE

Billy Hawley
Owner

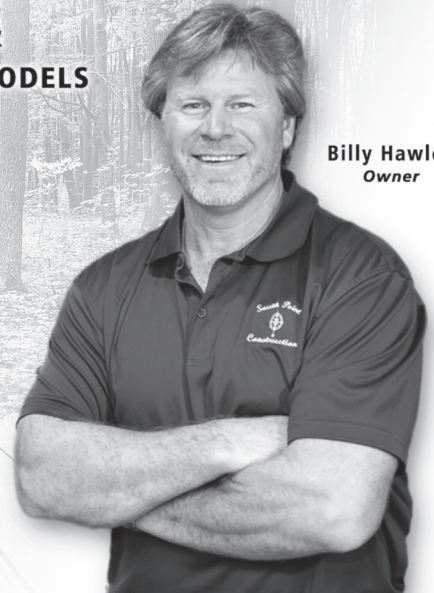

**SOUTH POINT
CONSTRUCTION**

renovations | new homes | old values

(803) 648-9399 | SOUTHPOINTCONSTRUCTION.NET

Marvel Financial

Specialist in critical care solutions and other insurance needs of seniors 60-85. Protect against the financial impact of a serious illness. For a proposal based on your need and budget, Contact: Richard Marvel 781 258 9121 or marvelinaiken@gmail.com

Aiken Backyard Collections

Info@aikenbackyard.com

(803) 221-1566

Or see us on the web @ aikenbackyard.com

Just say "Yes" to JESUS
Outdoor Furniture Made from RECYCLE Milk Jugs



Welcome to Lee Nails!

(Located inside the Aiken Mall next to Belk)

(803) 648-1999

Open seven days a week.

Managed by:
Tony and Sonya Nguyen
(Woodside Residents)

Present this coupon for \$2.00 off! **Must be combined with any other offer.

By agreeing to display business ads, the WPPPOA is not endorsing or recommending the use of any advertiser. The decision on which businesses to use is left entirely to the homeowners. To place an ad, call Woodside Property Owners' Association 641-9663, and ask for Keena Adams or email keena@wpppoa.com
Advertising prices per month: Business Card \$35, Quarter Page \$55 and Half Page \$85.



Beard **LAWN CARE**

Owner: Steve Beard • 803.641.7404 • 145 Winged Elm Circle
Providing Lawn Care Services to My Residential Community
Call for a FREE consultation today!



VETERINARY HOSPICE
& In-Home Euthanasia

DR. SUNDAY COZZI &
DR. NANCY RODRIGUEZ
(803) 994-9460

Compassionate in-home
end of life care for pets.

www.LapofLove.com
CSRA@LapofLove.com



WOODSIDE ADVANCED MASSAGE

FEEL WELL / MOVE WELL

Relaxation
Stress Reduction
Fatigue Management
Life Related Injuries

Advanced therapies
for conditions such as
MS, Lupus, Fibromyalgia,
and Lymphedema

Woodside Executive Park
803.522.2296

Tuesday through Saturday by Appointment



Room Additions
Kitchens
Baths



Termite Repair
Windows
and more

J.D. Norris Construction Co., Inc.

"Your Remodeling Specialist"

803-593-4587

www.jdnorrisremodel.com

J. D. & Cheryl Norris - Owners



**DreamMaker
Bath & Kitchen**

ENHANCING LIVES. IMPROVING HOMES.

803-593-9191
jdn.dm@comcast.net
www.dreammakeraiken.com

KIM COOPER

Helping You Make the Right Move.

Cell: (803) 474-3578 | Office: (803) 644-1727
kcooper@meybohm.com findaikenrealstate.com

The Right Move...

When it comes time
for your next move,
don't take a chance
with just any agent.
Call the expert in
Aiken Real Estate,
KIM COOPER
to help you make the
right move!



Meybohm
REALTORS®



By agreeing to display business ads, the WPPOA is not endorsing or recommending the use of any advertiser. The decision on which businesses to use is left entirely to the homeowners. To place an ad, call Woodside Property Owners' Association 641-9663, and ask for Keena Adams or email keena@wpboa.com

Advertising prices per month: Business Card \$35, Quarter Page \$55 and Half Page \$85.

May 2015.

WOODSIDE PROPERTY OWNERS CLASSIFIED ADS

G&S COMPUTING

SOFTWARE | HARDWARE | NETWORKING

803-641-9943 www.gscompinc.com



On-site and Drop-Off Services Available

Common Services Include:

- Malware Removal
- Computer Repair/Upgrades
- Network Setup/Diagnostics
 - Wireless Solutions
 - Device Configuration



37 Capital Drive
Aiken, SC 29803



TURFTEC
LANDSCAPE & DESIGN

**NEW YEAR
NEW CLIENT DRIVE**

Call Today For
Your Free Estimate!
Phone: (803) 292-9597
www.TurfTecLandscape.com

Now taking new clients for:
-Landscape Maintenance
-Fertilization Programs
-Landscape Projects



Computerized Engine Analysis
Professional Import and Domestic Auto Service

AUTO TECH, INC.

643-9266

460 Silver Bluff Road
Aiken, SC 29803



Steve Young

Owner



SOLATUBE®

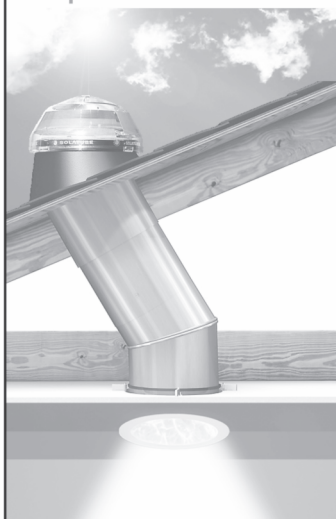

Ideal for:

- Bathrooms
- Hallways
- Closets
- Laundry Rooms
- Dens
- Home Offices
- Kitchens
- Dining Rooms
- Family Rooms

For More Information, Contact:

Brighter Solutions 803.551.1026

www.BrighterSolutionsSC.com



**EASY & QUICK
CAR WASH**

765 Silver Bluff Rd Open 24 Hours
Aiken, SC 29803 803.295.9075

FREE VACUUM with Any
Touch Free Automatic Car Wash



To place an ad, call
Woodside Property Owners' Association
641-9663, and ask for
Keena Adams or email keena@wppoa.com

By agreeing to display business ads, the WPPPOA is not endorsing or recommending the use of any advertiser. The decision on which businesses to use is left entirely to the homeowners. To place an ad, call Woodside Property Owners' Association 641-9663, and ask for Keena Adams or email keena@wppoa.com

Advertising prices per month: Business Card \$35, Quarter Page \$55 and Half Page \$85.

May 2015.

WOODSIDE PROPERTY OWNERS' CLASSIFIED ADS

*There's No Place
Like Home s.v.c.*

In-home petsitting services

Exceptional care
given to your pet in
their own home.

419-378-1126

Insured. References provided.



*Fresh
Perspectives*

*Residential and Commercial Cleaning Services
Free Estimates*

Licensed, Insured and Bonded

Deborah Birmingham, Owner
Email: housekpr5@aol.com

Serving Aiken Since 2000
(803) 439-6318 Mobile

AFFORDABLE

Home Repairs

All Types of Home Improvements

Windows & Doors



**We Sell, Install & Service
Anderson, Pella & All Major Brands
Call For A Free In Home Consultation
Today (803) 979-4189
www.affordablescga.com**



**Stay at home
alternatives**

from the professionals
at Right at Home

**Right
at
Home®**

In Home Care & Assistance

*For more information and a free in-home
assessment, call*

803-648-7616

or visit www.rightathome.net/csra.

*"Right at Home" owners Celeste Hoffman and Kathy Crist introduce
therapy dog Snickers to Mrs. Margaret Lista. Photo by Todd Lista.*

By agreeing to display business ads, the WPPOA is not endorsing or recommending the use of any advertiser. The decision on which businesses to use is left entirely to the homeowners. To place an ad, call Woodside Property Owners' Association 641-9663, and ask for Keena Adams or email keena@wpboa.com

Advertising prices per month: Business Card \$35, Quarter Page \$55 and Half Page \$85.

May 2015.